

AUTOSOFT – DIAGNOSTIC SERVER SDK

Automotive Diagnostic Software Development Kit

DIAGNOSTIC SERVER OVERVIEW

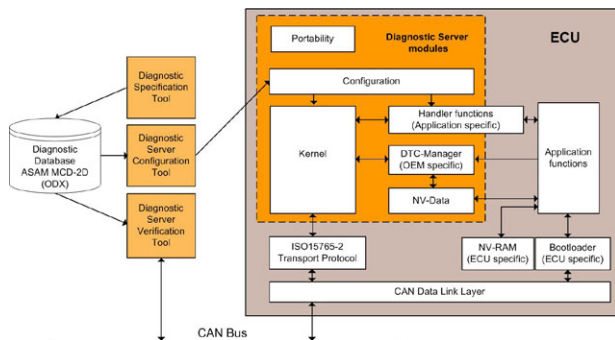

Electronic Control Units developed for automotive and commercial vehicle systems contains Diagnostic functionality. These functions are accessed through diagnostic communication protocols such as Unified Diagnostic Services ISO 14229 (UDS), ISO 14230 (KWP2000) or GMW3110.

The Mecel Diagnostic Server SDK gives the diagnostic application developer a common framework independent from the communication protocol and the possibility to have uniform implementation across different systems and products. By providing tools for configuration, adaptation and verification, the customer has full support through the different development stages. ■■■

THE AUTOSOFT – DIAGNOSTIC SERVER SDK

The Autosoft – Diagnostic Server Software Development Kit (SDK) is a high-quality software building block for diagnostics communication, including the tool support necessary to create and verify its correct integration onto the target system.

It includes the software modules needed to create a diagnostic communication server on the target system, including hooks to integrate different diagnostic trouble code managers, transport modules, bootloader and non-volatile data management.

The Autosoft – Diagnostic Server SDK is platform independent. A portability module allows the user to adapt the server for a specific platform, and the configuration tool automatically configures the diagnostics services from the standardised ODX (Open Diagnostics Data Exchange) database.

FEATURES

- Support for major protocol standards
 - ISO 14229 UDS
 - ISO 14230 (KWP2000)
 - GMW3110
- Configurable from a standard ASAM-MCD-2D ODX database
- Adhere to MISRA/C rules and recommendations
- Robust
- Resource efficient
- Flexible, easy to adapt to HW/SW platform

DIAGNOSTIC SERVER SDK INTEGRATION WORKFLOW

The Autosoft diagnostic server is easy to integrate.

The following steps are typically performed:

- I Modify portability module
Effective scheduling of kernel, transport layer adaptation.
Compile and link for target.
- II Verify target communication
Through default application hooks the platform adaptation is verified.
- III Configure the Diagnostic Server
Generate diagnostic services from ODX database.
Implement application diagnostic hooks.
- IV Verify correctness on target
Use Automated Diagnostic Verification Tool to read ODX database and verify target implementation.



TECHNICAL SPECIFICATION DIAGNOSTIC SERVER SDK

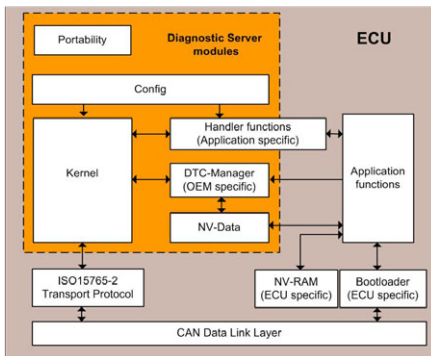

Portability

The Portability module encapsulates the differences between platforms, effectively interaction with operating system, compilers and transport protocols.

Config

The Config module contains definitions for the sessions and services that will be supported by the ECU. The Config module is generated by the Configuration Tool.

DTC Manager

The DTC Manager module manages all status information related to DTCs. It provides DTC information to the kernel when requested by the Tester. The Application reports test status (passed or failed) to the DTC Manager each time a test for a specific DTC has been performed. Identifiers for all supported DTCs, as well as DTC specific filter handling are generated by the Configuration Tool.

NV-Data

The NV-Data module encapsulates Diagnostic server variables that need to be stored in a non-volatile memory while the ECU is not powered. It provides a function interface for the

Application to transfer the data from the non-volatile memory to the NV-Data module at start-up, and to store the updated data in the non-volatile memory when required.

Kernel

The Kernel module is the core module of the diagnostic server. It contains the service handlers required to receive and parse diagnostic request messages that are sent from a tester. It is also responsible for composing and sending the response message back to the tester.

STANDARDISED DATABASE SUPPORT

Autosoft – Diagnostic Server SDK supports standardised database approach to be consistent and flexible throughout the development process. The database standard is ODX, an XML-format developed by ASAM-MCD-2D. ODX provides a well defined exchange format for diagnostic requirement specifications. The model lends itself to automated configuration and generation of target code, and also for automated test and validation of implementation correctness.

PRODUCT DELIVERABLES

- Diagnostic Server Software
- Diagnostic Server User Manual
- Diagnostic Server configuration tool
- Diagnostic Server verification tool

Optional Deliverables

- ISO 15765-2 compliant Transport Module
- CAN Data Link Layer
- Diagnostic Client SDK

Supplemental Services

- Software adaptation and configuration services
- Diagnostic communication expert consultation

For more information, please go to www.mecel.se ■ ■ ■

About Mecel

Mecel is a systems and software development company with more than 25 years of experience in developing solutions for the automotive industry. We specialize in in-car communication technologies, user interface development and consumer device interaction. As engineering consultants, we are pioneering state-of-the-art technology to produce innovative and efficient solutions that provide our clients with a definite competitive edge. We are skilled in taking on the entire procedure from initial R&D work to development and testing of the final products. ■ ■ ■

CONTACT US

Mecel AB

Box 14044
SE-400 20 Göteborg, Sweden

Visiting address

Mölnadalsvägen 36, Göteborg

Phone +46 31 720 44 00

www.mecel.se

